



## Kew Court Apartments

London, W4 3AF



### Access to the block.

**The pedestrian entrance** into the complex can be located opposite Kew Bridge Station. To enter into the complex enter code **door symbol 5555 door symbol** into the key pad located next to the pedestrian gate. Once guests have retrieved their mailbox pack, they will have a fob attached to their key set which can also be used.

**Side entrance to the complex (to the right of block containing 84-89).** A side entrance to the complex can be located to the right of the block containing apartments 75-82. The side gate code is C6492X



### How To Access Your Apartment.

**A fob is required to enter the building.** This will have been provided in the guests' mailbox pack, attached to their key set. They should wave this in front of the building entry system (located on the left of the door) until they hear the door release. The communal stairwell is located off of the ground floor lobby.

**Apartment 84, 86, 88 and 89:** Continue along Kew Bridge Court Road, take the second turning on the right and the apartment block will be on your right-hand side.

**Apartment 4:** Continue through the pedestrian gate, proceed to the concierge office on your left and turn left. Follow the path down and the building entrance is on your left.

**Apartment 61 and 68:** Continue through the pedestrian gate, follow the road through the complex and the block will be on your right hand side.



**To exit the building** - A door release button can be located in the ground floor foyer

**Access to the car park.**

**The car park entrance** is located alongside the pedestrian entrance. If guests have requested parking, they will need to park their car at the front gates and enter the development through the pedestrian gate (**code 9404**). The guest will then need to proceed to their apartment mailbox to retrieve the envelope containing their apartment keys, zapper and parking permit. The guest should then return back to their car and open the gates using the zapper – permits should be placed facing upwards on the dashboard. The carpark can be located in the centre of the development, parking bays are on a first come first serve basis. Parking permits are to be displayed to avoid clamping and a fine.

Residents without a permit and fob can't open the front vehicle gate and they have to use the pedestrian gate) door symbol 5555 door symbol), if they are expecting a delivery then the couriers need to press 66 on the intercom and your guests can open the vehicle gate.

**Mail:** all mailboxes can be located on the outside of each building wall.

**Refuse store:** can be located in the car park. Please ensure all waste is bagged and that no over-sized items are left in the refuse store.

**Emergency water shut off:** can be located in the lounge or hallway cupboard.

**Power:** If you experience any problems with your power or light bulbs blowing during your stay please note that you have a fuse box located in your apartment which can be located in the hallway cupboard. Please ensure that all of the switches are on the up / on position.

**Heating and Hot Water:** controlled by the central Centaurplus control panel located in the hallway.

The individual radiators can also be adjusted using the dial located on the bottom left of the radiators and a central thermostat dial to adjust the overall ambient temperature can be located in the hallway.



### The CentaurPlus C11 Timeswitch

The simple instructions contained in this user guide are designed to help with the programming and operation of the unit.

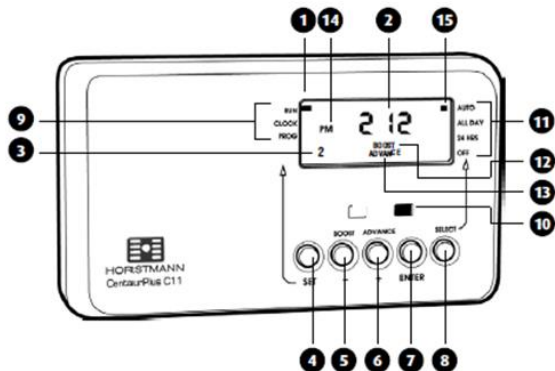

- 1 SET indicator - RUN is the normal position
- 2 Time of day
- 3 Switch period symbol
- 4 SET button
- 5 BOOST or adjust (-) button
- 6 ADVANCE or adjust (+) button
- 7 ENTER button
- 8 SELECT button
- 9 SET positions
- 10 System ON indicator
- 11 PROGRAMME positions
- 12 BOOST symbol
- 13 ADVANCE symbol
- 14 AM/PM symbol
- 15 PROGRAMME indicator

### Programme Override Facilities

With the CentaurPlus C11 timeswitch operating in the normal running mode it is possible to alter the functionality of the programme by means of the SELECT button. The options include;

- AUTO** - Timeswitch follows all programmed 'ON' and 'OFF' times.
- ALL DAY** - Timeswitch operates from 1st 'ON' time until 3rd 'OFF', ignoring all switching times in between.
- 24hrs** - Timeswitch will be constantly 'ON'.
- OFF** - Timeswitch will be constantly 'OFF', there is the ability to turn off the heating during the summer without altering the programme times. Boost is still available.

All of the settings above will be permanent, i.e. unaffected by programme times, until alteration by the user.

The diagram below illustrates how to alter the setting, it assumes that the programme is in the AUTO mode to begin with.

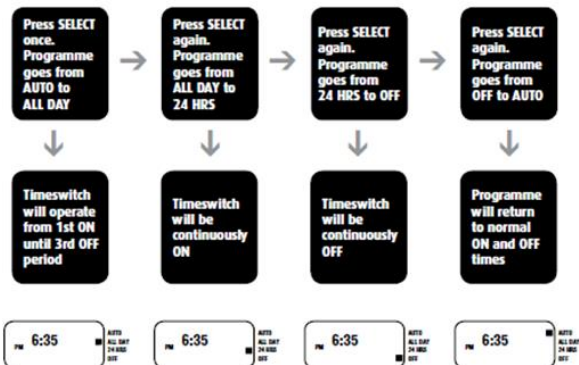

### Manual Overrides

#### BOOST FUNCTION - 1 HOUR TEMPORARY OVERRIDE

The boost facility will allow the user to boost the system which is currently 'OFF' for 1 hour. To indicate the boost being activated BOOST will be shown on the display for the duration of the boost period. The system ON indicator will also be illuminated.

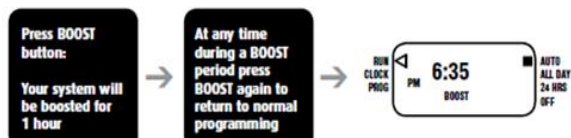

#### ADVANCE FUNCTION - BRINGS FORWARD THE NEXT ON OR OFF OPERATION

The advance facility will allow the user to advance the system to 'ON' when currently 'OFF' or switch the system 'OFF' when currently 'ON'. To indicate the advance feature being activated ADVANCE will be shown on the display until the next programme switching time. The system ON indicator will also be illuminated.

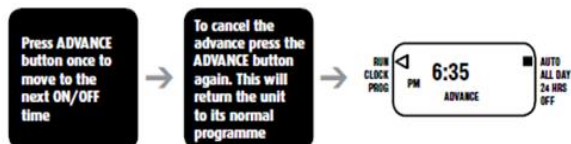

### Setting the Time of Day

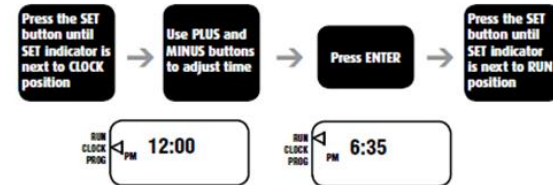

#### DEFAULT TIME SETTINGS

1st ON	1st OFF	2nd ON	2nd OFF	3rd ON	3rd OFF
6.30AM	8.30AM	12.00PM	12.00PM	4.30PM	10.30PM

The default time settings shown above are preset at the factory

### Setting the On and Off Times

To alter these settings please proceed as follows:-

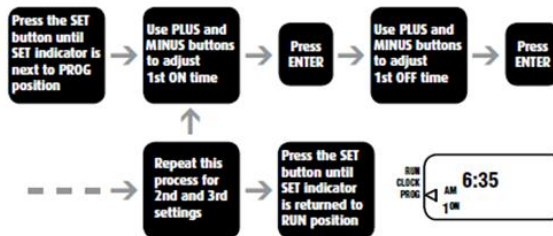

NB. The factory default settings for the 2nd ON/OFF times are both set at 12:00pm (midday) which cancels this 'ON' period giving 2 ON/OFF periods for 24hrs. If a midday 'ON' period is required set the 2nd ON and OFF times accordingly. If not press ENTER twice.

**Kitchen Fuses:** can be located on a panel with the light switches within the kitchen, just before the worktop.

# ROOM SPACE

**Bathroom:** Heated towel rails are provided in the bathrooms, these are on the same programme as the apartment radiators. Please ensure that the towel rails are switched on at the main power switch which can be located either on the wall outside of the bathroom or in the lounge cupboard.

